



# 3.3V CMOS 16-BIT BUS TRANSCEIVER WITH 3-STATE OUTPUTS

IDT74ALVC16245

## FEATURES:

- 0.5 MICRON CMOS Technology
- Typical  $t_{sk(o)}$  (Output Skew) < 250ps
- ESD > 2000V per MIL-STD-883, Method 3015; > 200V using machine model (C = 200pF, R = 0)
- $V_{CC} = 3.3V \pm 0.3V$ , Normal Range
- $V_{CC} = 2.7V$  to  $3.6V$ , Extended Range
- $V_{CC} = 2.5V \pm 0.2V$
- CMOS power levels (0.4 $\mu$  W typ. static)
- Rail-to-Rail output swing for increased noise margin
- Available in TSSOP package

## DRIVE FEATURES:

- High Output Drivers:  $\pm 24mA$
- Suitable for heavy loads

## DESCRIPTION:

This 16-bit bus transceiver is built using advanced dual metal CMOS technology. The ALVC16245 is designed for asynchronous communication between data buses. The control-function implementation minimizes external timing requirements.

This device can be used as two 8-bit transceivers or one 16-bit transceiver. It allows data transmission from the A bus to the B bus or from the B bus to the A bus, depending on the logic level at the direction-control (DIR) input. The output-enable ( $\overline{OE}$ ) input can be used to disable the device so that the buses are effectively isolated.

The ALVC16245 has been designed with a  $\pm 24mA$  output driver. This driver is capable of driving a moderate to heavy load while maintaining speed performance.

## APPLICATIONS:

- 3.3V high speed systems
- 3.3V and lower voltage computing systems

## FUNCTIONAL BLOCK DIAGRAM

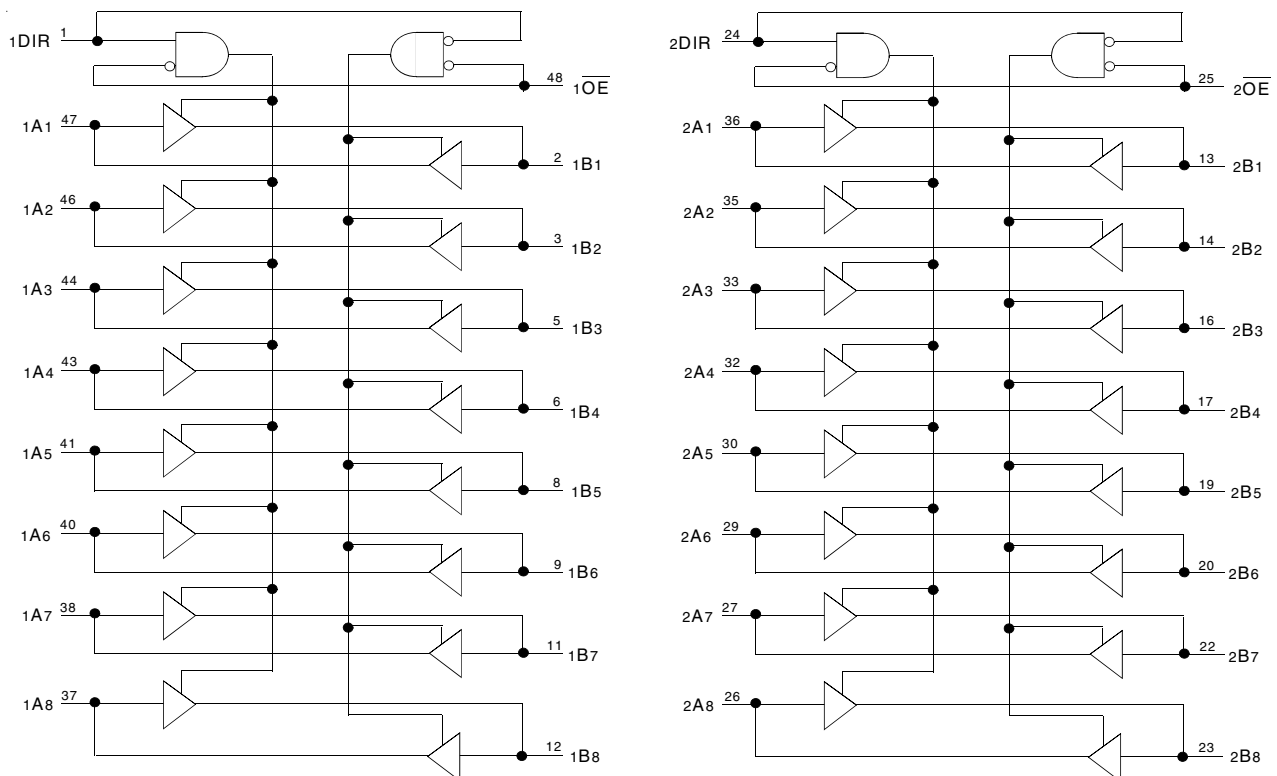

The IDT logo is a registered trademark of Integrated Device Technology, Inc.

INDUSTRIAL TEMPERATURE RANGE

OCTOBER 2008

## PIN CONFIGURATION

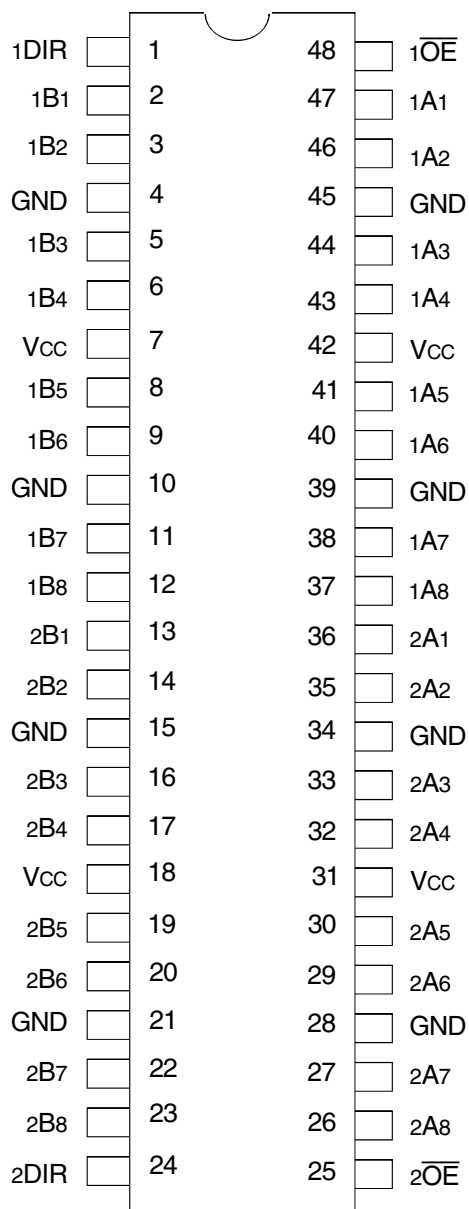

TSSOP  
TOP VIEW

## ABSOLUTE MAXIMUM RATINGS<sup>(1)</sup>

Symbol	Description	Max	Unit
V <sub>TERM</sub> <sup>(2)</sup>	Terminal Voltage with Respect to GND	-0.5 to +4.6	V
V <sub>TERM</sub> <sup>(3)</sup>	Terminal Voltage with Respect to GND	-0.5 to V <sub>CC</sub> +0.5	V
T <sub>STG</sub>	Storage Temperature	-65 to +150	°C
I <sub>OUT</sub>	DC Output Current	-50 to +50	mA
I <sub>IK</sub>	Continuous Clamp Current, V <sub>I</sub> < 0 or V <sub>I</sub> > V <sub>CC</sub>	±50	mA
I <sub>OK</sub>	Continuous Clamp Current, V <sub>O</sub> < 0	-50	mA
I <sub>CC</sub> I <sub>SS</sub>	Continuous Current through each V <sub>CC</sub> or GND	±100	mA

### NOTES:

- Stresses greater than those listed under ABSOLUTE MAXIMUM RATINGS may cause permanent damage to the device. This is a stress rating only and functional operation of the device at these or any other conditions above those indicated in the operational sections of this specification is not implied. Exposure to absolute maximum rating conditions for extended periods may affect reliability.
- V<sub>CC</sub> terminals.
- All terminals except V<sub>CC</sub>.

## CAPACITANCE (T<sub>A</sub> = +25°C, F = 1.0MHz)

Symbol	Parameter <sup>(1)</sup>	Conditions	Typ.	Max.	Unit
C <sub>IN</sub>	Input Capacitance	V <sub>IN</sub> = 0V	5	7	pF
C <sub>OUT</sub>	Output Capacitance	V <sub>OUT</sub> = 0V	7	9	pF
C <sub>OUT</sub>	I/O Port Capacitance	V <sub>IN</sub> = 0V	7	9	pF

### NOTE:

- As applicable to the device type.

## PIN DESCRIPTION

Pin Names	Description
x $\overline{OE}$	Output Enable Inputs (Active LOW)
xDIR	Direction Control Inputs
xAx	Side A Inputs or 3-State Outputs
xBx	Side B Inputs or 3-State Outputs

## FUNCTION TABLE (EACH 8-BIT SECTION)<sup>(1)</sup>

Inputs		Outputs
x $\overline{OE}$	xDIR	
L	L	Bus B Data to Bus A
L	H	Bus A Data to Bus B
H	X	Z

### NOTE:

- H = HIGH Voltage Level  
X = Don't Care  
L = LOW Voltage Level  
Z = High-Impedance

## DC ELECTRICAL CHARACTERISTICS OVER OPERATING RANGE

Following Conditions Apply Unless Otherwise Specified:

Operating Condition:  $T_A = -40^{\circ}\text{C}$  to  $+85^{\circ}\text{C}$

Symbol	Parameter	Test Conditions		Min.	Typ. <sup>(1)</sup>	Max.	Unit
$V_{IH}$	Input HIGH Voltage Level	$V_{CC} = 2.3\text{V}$ to $2.7\text{V}$		1.7	—	—	V
		$V_{CC} = 2.7\text{V}$ to $3.6\text{V}$		2	—	—	
$V_{IL}$	Input LOW Voltage Level	$V_{CC} = 2.3\text{V}$ to $2.7\text{V}$		—	—	0.7	V
		$V_{CC} = 2.7\text{V}$ to $3.6\text{V}$		—	—	0.8	
$I_{IH}$	Input HIGH Current	$V_{CC} = 3.6\text{V}$	$V_I = V_{CC}$	—	—	$\pm 5$	$\mu\text{A}$
$I_{IL}$	Input LOW Current	$V_{CC} = 3.6\text{V}$	$V_I = \text{GND}$	—	—	$\pm 5$	$\mu\text{A}$
$I_{OZH}$	High Impedance Output Current (3-State Output pins)	$V_{CC} = 3.6\text{V}$	$V_O = V_{CC}$	—	—	$\pm 10$	$\mu\text{A}$
$I_{OZL}$			$V_O = \text{GND}$	—	—	$\pm 10$	
$V_{IK}$	Clamp Diode Voltage	$V_{CC} = 2.3\text{V}$ , $I_{IN} = -18\text{mA}$		—	-0.7	-1.2	V
$V_H$	Input Hysteresis	$V_{CC} = 3.3\text{V}$		—	100	—	mV
$I_{CCL}$ $I_{CCH}$ $I_{CCZ}$	Quiescent Power Supply Current	$V_{CC} = 3.6\text{V}$ $V_{IN} = \text{GND}$ or $V_{CC}$		—	0.1	40	$\mu\text{A}$
$\Delta I_{CC}$	Quiescent Power Supply Current Variation	One input at $V_{CC} - 0.6\text{V}$ , other inputs at $V_{CC}$ or $\text{GND}$		—	—	750	$\mu\text{A}$

**NOTE:**

1. Typical values are at  $V_{CC} = 3.3\text{V}$ ,  $+25^{\circ}\text{C}$  ambient.

## OUTPUT DRIVE CHARACTERISTICS

Symbol	Parameter	Test Conditions <sup>(1)</sup>		Min.	Max.	Unit
$V_{OH}$	Output HIGH Voltage	$V_{CC} = 2.3\text{V}$ to $3.6\text{V}$	$I_{OH} = -0.1\text{mA}$	$V_{CC} - 0.2$	—	V
		$V_{CC} = 2.3\text{V}$	$I_{OH} = -6\text{mA}$	2	—	
		$V_{CC} = 2.3\text{V}$	$I_{OH} = -12\text{mA}$	1.7	—	
		$V_{CC} = 2.7\text{V}$		2.2	—	
		$V_{CC} = 3\text{V}$		2.4	—	
		$V_{CC} = 3\text{V}$		$I_{OH} = -24\text{mA}$	2	
$V_{OL}$	Output LOW Voltage	$V_{CC} = 2.3\text{V}$ to $3.6\text{V}$	$I_{OL} = 0.1\text{mA}$	—	0.2	V
		$V_{CC} = 2.3\text{V}$	$I_{OL} = 6\text{mA}$	—	0.4	
			$I_{OL} = 12\text{mA}$	—	0.7	
		$V_{CC} = 2.7\text{V}$	$I_{OL} = 12\text{mA}$	—	0.4	
		$V_{CC} = 3\text{V}$	$I_{OL} = 24\text{mA}$	—	0.55	

**NOTE:**

1.  $V_{IH}$  and  $V_{IL}$  must be within the min. or max. range shown in the DC ELECTRICAL CHARACTERISTICS OVER OPERATING RANGE table for the appropriate  $V_{CC}$  range.  
 $T_A = -40^{\circ}\text{C}$  to  $+85^{\circ}\text{C}$ .

OPERATING CHARACTERISTICS,  $T_A = 25^\circ\text{C}$

Symbol	Parameter	Test Conditions	$V_{CC} = 2.5V \pm 0.2V$	$V_{CC} = 3.3V \pm 0.3V$	Unit
			Typical	Typical	
CPD	Power Dissipation Capacitance Outputs enabled	$C_L = 0\text{pF}$ , $f = 10\text{MHz}$	22	29	pF
CPD	Power Dissipation Capacitance Outputs disabled		4	5	

SWITCHING CHARACTERISTICS<sup>(1)</sup>

Symbol	Parameter	$V_{CC} = 2.5V \pm 0.2V$		$V_{CC} = 2.7V$		$V_{CC} = 3.3V \pm 0.3V$		Unit
		Min.	Max.	Min.	Max.	Min.	Max.	
$t_{PLH}$	Propagation Delay	1	3.7	—	3.6	1	3	ns
$t_{PHL}$	$xAx$ to $xBx$ or $xBx$ to $xAx$							
$t_{PZH}$	Output Enable Time	1	5.7	—	5.4	1	4.4	ns
$t_{PZL}$	$\overline{xOE}$ to $xAx$ or $xBx$							
$t_{PHZ}$	Output Disable Time	1	5.2	—	4.6	1	4.1	ns
$t_{PLZ}$	$\overline{xOE}$ to $xAx$ or $xBx$							
$t_{SK(O)}$	Output Skew <sup>(2)</sup>	—	—	—	—	—	500	ps

NOTES:

1. See TEST CIRCUITS AND WAVEFORMS.  $T_A = -40^\circ\text{C}$  to  $+85^\circ\text{C}$ .
2. Skew between any two outputs of the same package and switching in the same direction.

## TEST CIRCUITS AND WAVEFORMS

### TEST CONDITIONS

Symbol	V <sub>CC</sub> <sup>(1)</sup> = 3.3V ± 0.3V	V <sub>CC</sub> <sup>(1)</sup> = 2.7V	V <sub>CC</sub> <sup>(2)</sup> = 2.5V ± 0.2V	Unit
V <sub>LOAD</sub>	6	6	2 x V <sub>CC</sub>	V
V <sub>IH</sub>	2.7	2.7	V <sub>CC</sub>	V
V <sub>T</sub>	1.5	1.5	V <sub>CC</sub> / 2	V
V <sub>LZ</sub>	300	300	150	mV
V <sub>HZ</sub>	300	300	150	mV
C <sub>L</sub>	50	50	30	pF

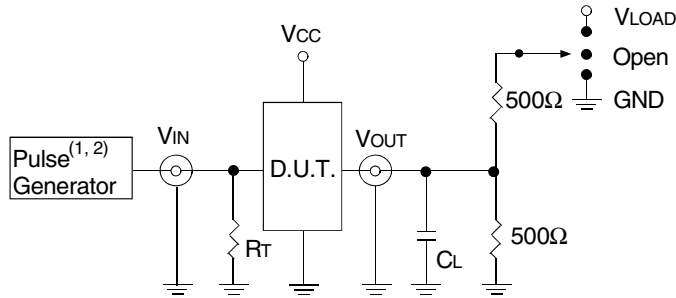

Test Circuit for All Outputs

#### DEFINITIONS:

C<sub>L</sub> = Load capacitance: includes jig and probe capacitance.  
R<sub>T</sub> = Termination resistance: should be equal to Z<sub>OUT</sub> of the Pulse Generator.

#### NOTES:

1. Pulse Generator for All Pulses: Rate ≤ 1.0MHz; t<sub>r</sub> ≤ 2.5ns; t<sub>r</sub> ≤ 2.5ns.
2. Pulse Generator for All Pulses: Rate ≤ 1.0MHz; t<sub>r</sub> ≤ 2ns; t<sub>r</sub> ≤ 2ns.

### SWITCH POSITION

Test	Switch
Open Drain Disable Low Enable Low	V <sub>LOAD</sub>
Disable High Enable High	GND
All Other Tests	Open

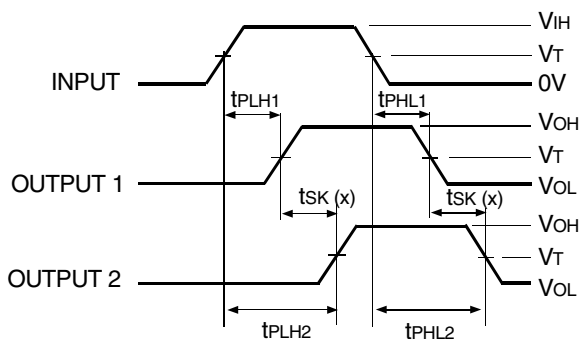

$$tsk(x) = |t_{PLH2} - t_{PLH1}| \text{ or } |t_{PHL2} - t_{PHL1}|$$

Output Skew - tsk(x)

#### NOTES:

1. For tsk(o) OUTPUT1 and OUTPUT2 are any two outputs.
2. For tsk(b) OUTPUT1 and OUTPUT2 are in the same bank.

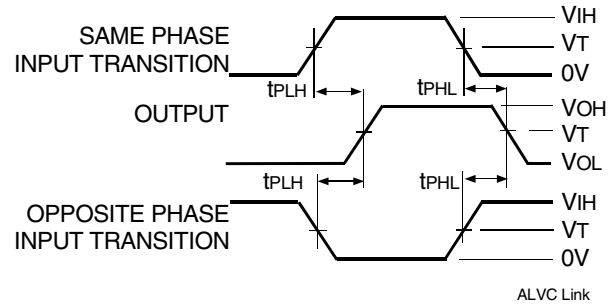

Propagation Delay

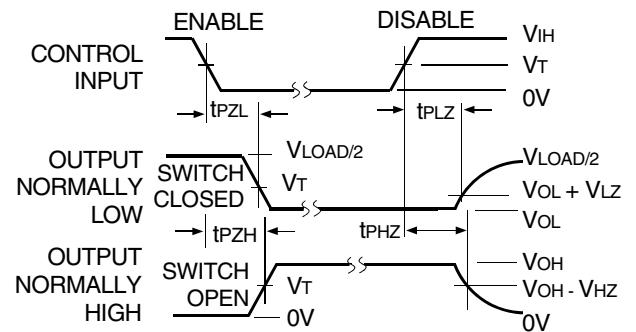

Enable and Disable Times

#### NOTE:

1. Diagram shown for input Control Enable-LOW and input Control Disable-HIGH.

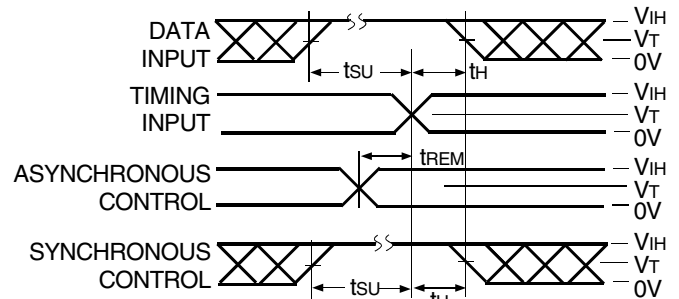

Set-up, Hold, and Release Times

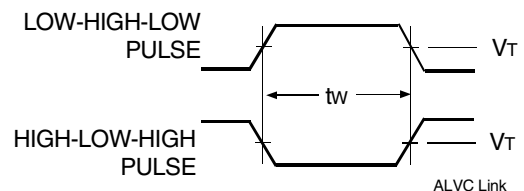

Pulse Width

**ORDERING INFORMATION**

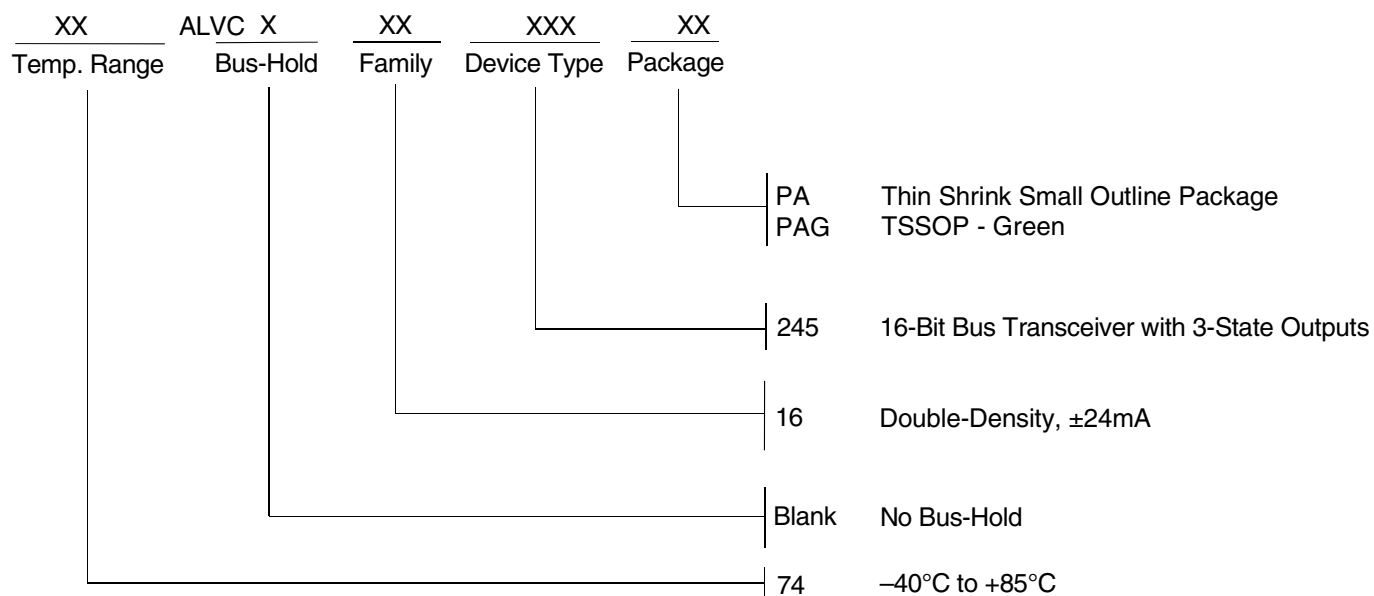

**CORPORATE HEADQUARTERS**  
 6024 Silver Creek Valley Road  
 San Jose, CA 95138

**for SALES:**  
 800-345-7015 or 408-284-8200  
 fax: 408-284-2775  
 www.idt.com

**for Tech Support:**  
 logichelp@idt.com